



**MOTORENFABRIK HATZ
D-94099 RUHSTORF • GERMANY**

Tel: 0 85 31 / 319-0 • Fax: 31 94 18
<http://www.hatz-diesel.de>
 eMail: marketing@hatz-diesel.de

The World Premiere

An air cooled one cylinder diesel engine
with vertical shaft

SUPRA
1D90V

5.5 - 11.8 kW • 7.5 - 16.0 HP

5 / 621 ENG Printed in Germany

Modifications, which serve the technical improvements, are reserved.



Design

- Aircooled single-cylinder fourstroke Diesel engines.
- Horizontal cylinder.
- Crankcase in light alloy, diecasting. Cylinder of grey cast iron.
- Cylinder head in light alloy.
- Crankshaft and big end in slide bearings.
- Direct injection, multi-hole nozzle.
- Valve control via camshaft, cam followers, pushrods and rockers.
- Pressure lubrication, with gear oil pump. On request oil filter in main flow.
- Light alloy oil sump cased with sheet steel.
- Flywheel fan, charging alternator integrated in the flywheel. No V-belt necessary.

Characteristics

- Denoised: emission of noise reduced to the absolute minimum by means of design features and precision of production.
- Low fuel consumption.
- Favourable exhaust gas values below ECE-R24.
- Robust: long engine life.
- Extensive interchangeability of parts within the engine family D.
- Reliable: since no V-belts.
- Easy to service: because automatic injection pump bleeding.
- Friendly to the environment: Ventilation of crankcase leads into the intake port.
- Automatic extra fuel device.
- Electric start.

Engine type	Dimensions (mm)		
	Lenght	Width	Height
1D90V	570	496	358

Technical data		1D90.	
Number of cylinders		1	
Bore x stroke	mm	104 x 85	
	inches	4.09 x 3.35	
Displacement	l	0.722	
	cu.in.	44.0	
Mean piston speed at 3000 r.p.m.	m/s	8.5	
	ft/min	1673	
Compression ratio		20.5	
Lub. oil consumption		approx. 1% of fuel consumption, related to full load	
Lub. oil capacity max. / min.	l	1.9 / 1.0	
	US qts	2.0 / 1.06	
Speed control	Idle speed	approx. 800 r.p.m.	
	Static speed droop	approx. 5% at 3000 r.p.m.	

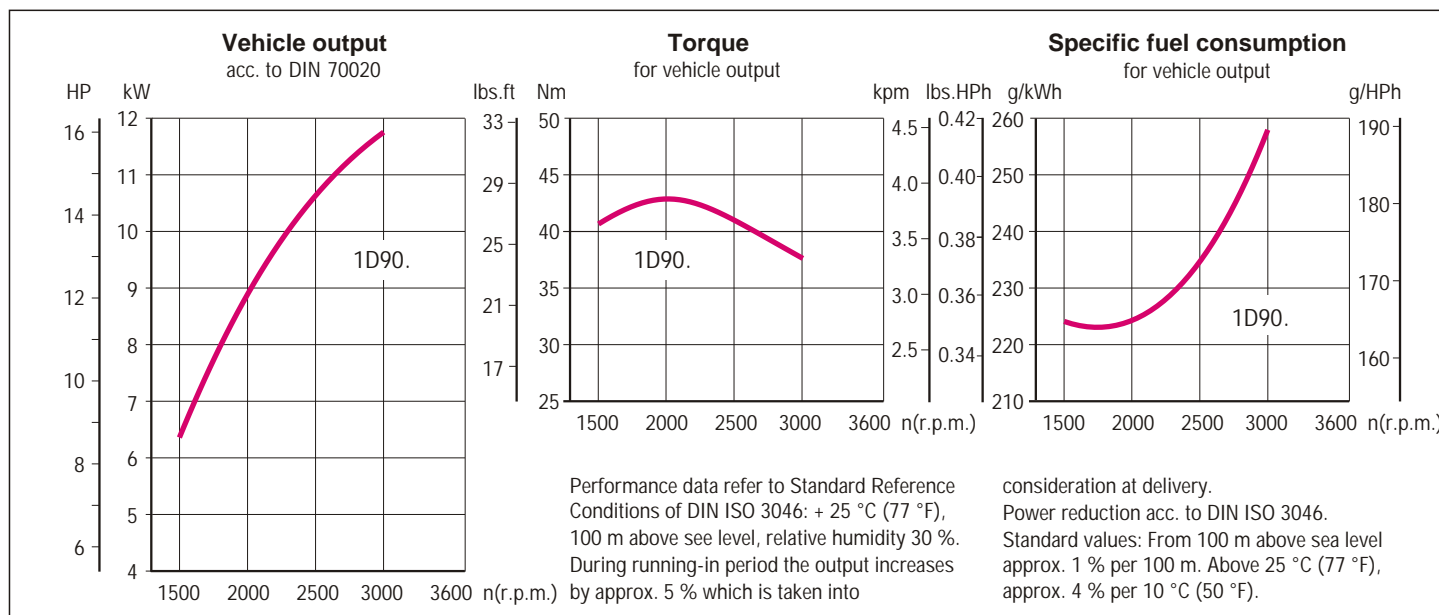

Performance table		1D90.		
	Hatz-Stand.	r.p.m.	kW	HP
ISO net brake fuel stop power (IFN) for intermittent load acc. to DIN ISO 3046.	B	3600	—	—
		3000	11.5	15.6
		2600	10.5	14.3
		2300	9.6	13.1
		2000	8.5	11.6
		1800	7.6	10.3
		1500	6.1	8.3
ISO-standard power (ICXN) (10% overload permissible) and ISO-standard fuel stop power (no overload permissible) acc. to DIN ISO 3046. For constant speed and constant load (ICFN).	S	3600	—	—
		3000	10.4	14.1
		2600	9.5	12.9
		2300	8.6	11.7
		2000	7.7	10.5
		1800	6.8	9.2
		1500	5.5	7.5

Power-Take-Off and Sense of Rotation

- Power-take-off at the flywheel A at engine speed.
- Power-take-off at the governor side B at engine speed (fig. 1).
- Sense of Rotation see figure 1.
- Engine can be flange-mounted at governor side and flywheel side.

Engine models

- 1D90V: counter-clockwise rotation (fig. 1), with 50% balancing of free mass forces.
- 1D90W: counter-clockwise rotation (fig. 1), with 100% balancing of free mass forces. (Referring to free mass forces of first order) (fig.2) .

Engine variants

- Variant XI : Engine with electric start 12 V, (figure 3).
- Variant XIII: Engine with electric start 24 V, (figure 3).

Weight

incl. tank, air filter and exhaust silencer	Variant XI		Variant XIII	
	kg	lbs.	kg	lbs.
1 D90V	85.9	189	85.9	189
1 D90W	88.0	194	88.0	194

Scope of Delivery of Engine

Engine tested for full load on test bench. Engine fitted with flywheel-fan, variable speed governor, dry-type air filter, automatic extra fuel device, automatic bleeding, eye-hook for transport of engine (only to carry weight of the engine).

Parts made of sheet metal painted black, crankcase of light alloy not painted.

No oil in engine.

Additional equipment: Tools and gaskets for 1st maintenance, instruction booklet, spare parts list and "Service International"

Further equipment included in engine variants:

- Variant XI : Starter 12 V, 1.5 kW, alternator 14 V, 16 A, cables, oil pressure switch, gearing
- Variant XIII: Starter 24 V, 1.5 kW, alternator 28 V, 9 A, cables, oil pressure switch, gearing

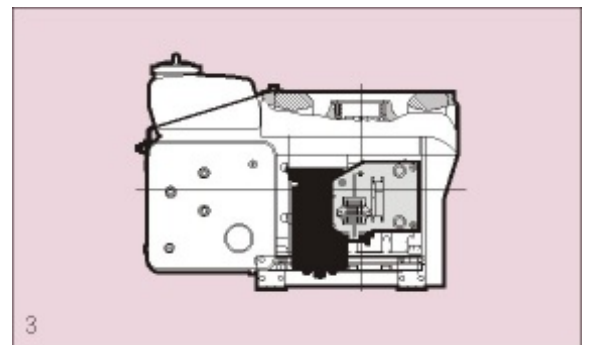
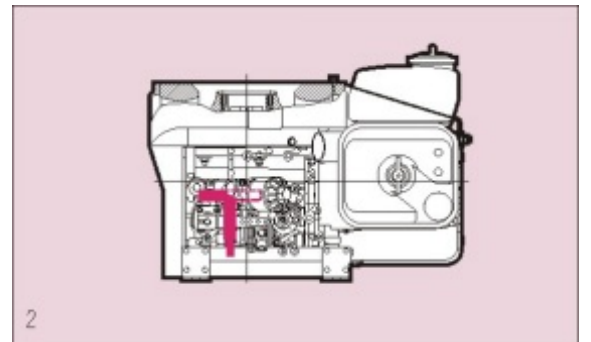
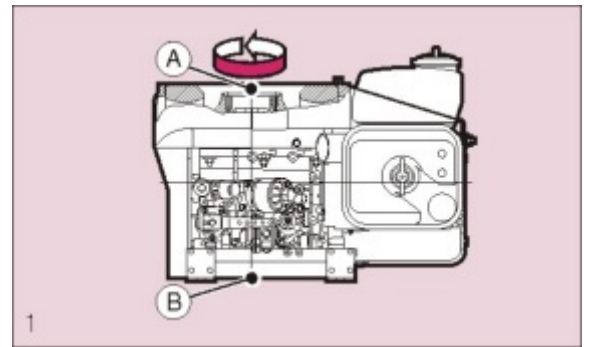

Additional equipment

Thanks to the complete programme of additional equipment every engine can be adapted to the special requirements of every application.

As a minimum every engine needs the "additional equipment, necessary for operation".