



**MOTORENFABRIK HATZ  
D-94099 RUHSTORF • GERMANY**

Tel: 0 85 31 / 319-0 • Fax: 31 94 18  
<http://www.hatz-diesel.de>  
 eMail: [marketing@hatz-diesel.de](mailto:marketing@hatz-diesel.de)

Multi-cylinder Diesel engines  
of modular design

**2M41 • 3M41 • 4M41**

**17.0 - 59.0 kW • 23.0 - 80.0 HP**

5 / 518 ENG Printed in Germany

Modifications, which serve the technical improvements, are reserved.

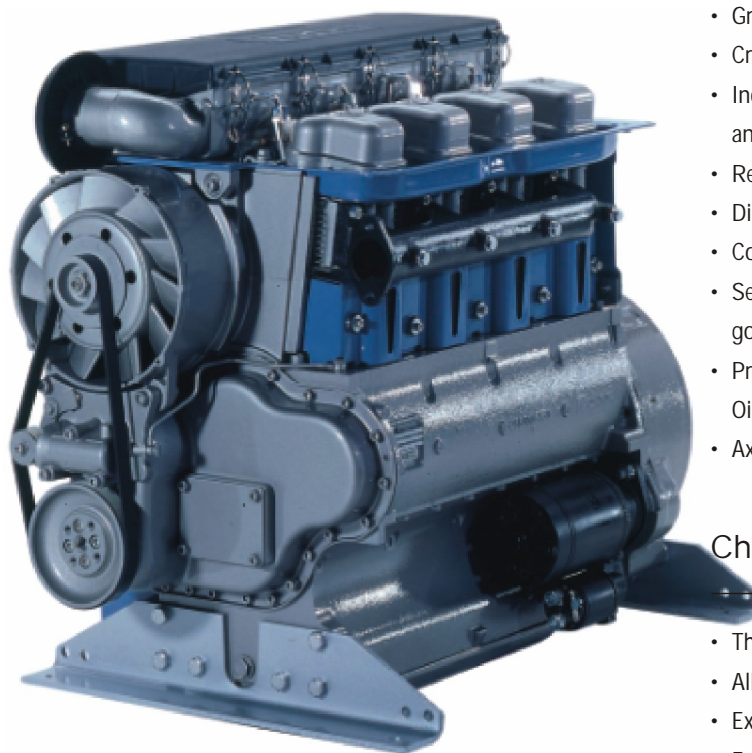

## Design

- Aircooled 2, 3 and 4-cylinder fourstroke Diesel engines.
- Grey cast iron crankcase, grey cast iron vertical in-line cylinders.
- Crankshaft and conrod running on shell-bearing.
- Individual cylinders (grey cast iron), individual cylinder-heads (light metall) and individual injection pumps.
- Removal of piston and conrod possible in upwards direction.
- Direct injection with multi-hole nozzle.
- Control of valves by rockers, pushrods, tappets and camshaft.
- Separate camshaft for drive of injection pumps with centrifugal variable speed governor and automatic injection timer.
- Pressure lubrication system with gear pump.  
Oilcooler and replaceable filter element in main flow.
- Axial-type blower fan with integrated alternator.

## Characteristics

- The Diesel engine ready for installation and operation.
- All-purpose industrial Diesel engines.
- Extremely low fuel- and oil consumption.
- Exhaust emission well below all valid limits for operating machines in EU, USA and Japan.
- Robust, and long-lived engine.
- Extensive parts interchangeability due to modular system.
- Low repair cost due to individual cylinders, individual cylinder-heads and individual injection-pumps.
- Unusual reliability because of:
  - Automatic belt control
  - Automatic extra fuel device
  - Dry-type airfilter, protected against severe contamination
  - Gearwheels to drive camshafts and oil pump
- Easy to service because of:
  - Automatic injection pump bleeding
  - Operating and maintenance points at one engine side only
  - Hydraulic belt tensioner

Engine type	Dimensions (mm)		
	Lenght	Width	Height
2M41	618	570	733
3M41	753	570	733
4M41	888	570	733

Technical data		2M41	3M41	4M41
Number of cylinders		2	3	4
Bore x Stroke	mm	102 x 105	102 x 105	102 x 105
	inches	4.02 x 4.13	4.02 x 4.13	4.02 x 4.13
Displacement	l	1.716	2.574	3.432
	cu.in.	104.7	157.0	209.4
Mean piston speed at 3000 r.p.m.	m/s	10.5	10.5	10.5
	ft/s	2067	2067	2067
Compression ratio		18.7	18.7	18.7
Lub. oil consumption		approx. 0.2% of fuel consumption, related to full load		
Lub. oil capacity max. / min.	l	5.5 / 3.0	8.5 / 5.0	14.0 / 5.0
	US qts	5.8 / 3.2	9.0 / 5.3	14.8 / 5.3
Speed control	Idle speed	approx. 800 r.p.m.		
	Static speed droop	approx. 5% at 3000 r.p.m.		

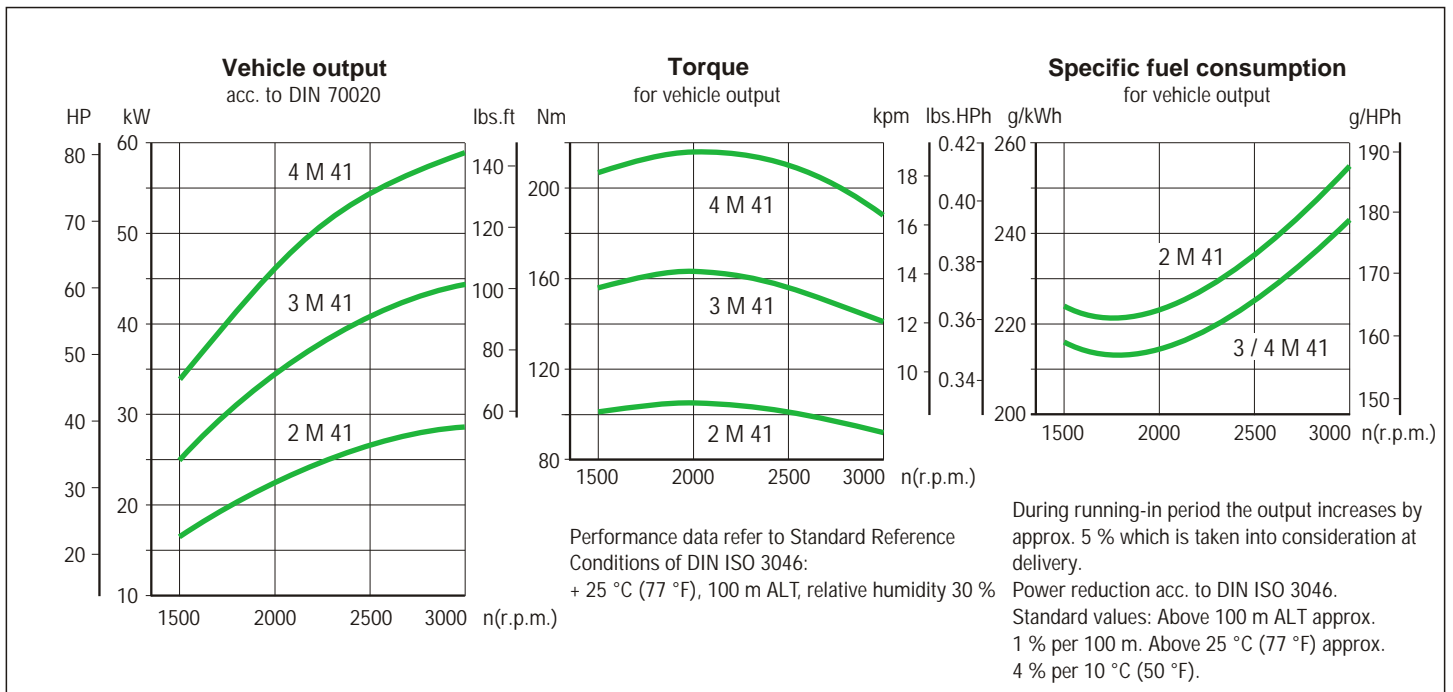

Performance table		2M41		3M41		4M41		
	Hatz-Stand.	r.p.m.	kW	HP	kW	HP	kW	HP
ISO net brake fuel stop power (IFN) for strongly intermittent load acc. to DIN ISO 3046.	B <sub>SI</sub>	3000	27.7	37.7	42.0	57.1	56.1	76.3
		2600	26.4	35.9	39.9	54.3	53.4	72.6
		2300	25.4	34.5	38.9	52.9	52.0	70.7
		2000	22.4	30.5	34.5	46.9	46.0	62.6
		1800	20.2	27.5	31.1	42.3	41.3	56.2
		1500	16.4	22.3	25.0	34.0	34.0	46.2
ISO net brake fuel stop power (IFN) for intermittent load acc. to DIN ISO 3046.	B	3000	26.3	35.8	39.8	54.1	53.1	72.2
		2600	25.0	34.0	37.8	51.4	50.6	68.8
		2300	25.4	34.5	38.9	52.9	52.0	70.7
		2000	22.4	30.5	34.5	46.9	46.0	62.6
		1800	20.2	27.5	31.1	42.3	41.3	56.2
		1500	16.4	22.3	25.0	34.0	34.0	46.2
ISO-standard power (ICXN) (10% overload permissible) and ISO-standard fuel stop power (no overload permissible) acc. to DIN ISO 3046. For constant speed and constant load (ICFN).	S	3000	23.7	32.2	35.8	48.7	47.8	65.0
		2600	22.5	30.6	34.0	46.2	45.5	61.9
		2300	22.9	31.1	35.0	47.6	46.8	63.6
		2000	20.2	27.5	31.1	42.3	41.4	56.3
		1800	18.2	24.8	28.0	38.1	37.2	50.6
		1500	14.8	20.1	22.5	30.6	30.6	41.6

Installation data		2M41	3M41	4M41
Combustion air required at 3000 r.p.m. approx. <sup>1)</sup>	m <sup>3</sup> / min	2.6	3.9	5.2
	cu.ft./min	92	138	184
Cooling air required at 3000 r.p.m. approx. <sup>1)</sup>	m <sup>3</sup> / min	29	39	49
	cu.ft./min	1024	1377	1730
Permanent tilting	max. degrees	30 <sup>2) 3) 4) 5)</sup>	25 <sup>2) 3) 4)</sup> 30 <sup>5)</sup>	25 <sup>4)</sup> 30 <sup>5)</sup> 15 <sup>2)</sup> 18 <sup>3)</sup>
Moment of inertia	SAE-flywheel 8"	0.64 kgm <sup>2</sup> (15.2 lb.ft <sup>2</sup> )	0.65 kgm <sup>2</sup> (15.4 lb.ft <sup>2</sup> )	0.67 kgm <sup>2</sup> (15.9 lb.ft <sup>2</sup> )
	flywheel for F+S clutch	0.49 kgm <sup>2</sup> (11.6 lb.ft <sup>2</sup> )	0.50 kgm <sup>2</sup> (11.9 lb.ft <sup>2</sup> )	0.51 kgm <sup>2</sup> (12.1 lb.ft <sup>2</sup> )
Starter motor		12 V - 2.7 kW (3.7 HP)		24 V - 4.0 kW (5.4 HP)
Alternator charging current at 3000 / 1500 r.p.m.		14 V - 50 / 42 A		28 V - 40 / 28 A
Battery capacity	min / max Ah	12 V - 88 / 143 Ah		24 V - 55 / 110 Ah

1) For other r.p.m. there is a linear reduction of the air requirement

2) Applicable for flywheel up

3) Applicable for flywheel low

4) Applicable for oilfilter low

5) Applicable for oilfilter up

## Permissible load on power-take-off points

### Flywheel:

Power-take-off at full engine torque.

- max. permissible axial force F2 = 2700 N
- max. permissible radial force F1

$$F1 = \frac{400\,000}{L1\text{ (mm)} - 73} \text{ (N)}$$

This data decreases by half if the direction of belt tension is upwards. If the radial force exceeds the permissible data F1 an outboard-bearing is necessary.

### Drive pulley R:

- max. permissible torque 32 Nm
- max. permissible axial force F4 = 1770 N
- max. permissible radial force F3 (belt tension in any direction)

$$F3 = \frac{228\,330}{L2\text{ (mm)} - 76} \text{ (N)}$$

All power-take-offs = engine speed

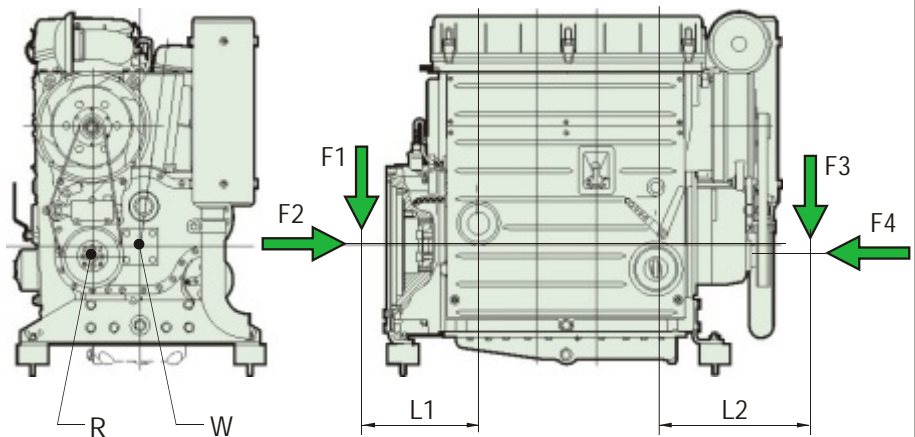

Shaft W: Max. permissible torque 70 Nm. Axial and radial forces not permitted.  
Suitable for hydraulic pump-drive.

## Maintenance- and operating points

For the engine to achieve its maximum life, it is essential that the engine is serviced meticulously at regular intervals.

The easier the accessibility is, the sooner and more conscientious the engine will be maintained.

Please convince yourself personally that all service and operation points are easily accessible before delivering your machine to the customer.

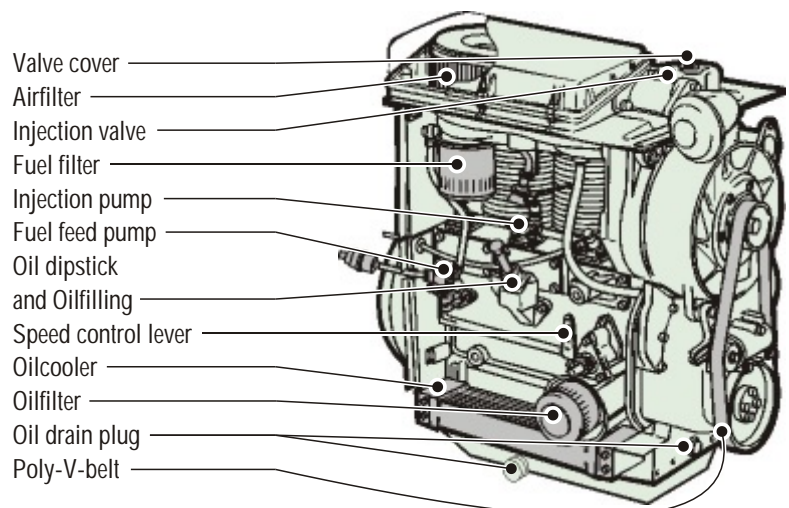

## Electrical equipment

The engine mounted components, such as starter, alternator and switches are connected to the instrument box by means of a 2 m cable harness. The engine is started and controlled from this instrument box. Instrument box and cable harness are part of the additional equipment and supplied according to the number of electrical safety features

which are required. If the engine has to be started at temperatures below - 15 °C, engine must be equipped with a pre-heating system (glow plug) (additional equipment). Further additional equipments include automatic start and stop, remote control etc.

Please ask for drawings and wiring diagrams.

# 2M41 • 3M41 • 4M41

## Power-take-off and Sense of Rotation

- Main power-take-off at flywheel (pict. 1).
- Power-take-off crankshaft governor side with engine speed. Maximum permissible torque 70 Nm, radial forces not permissible but for drive of hydraulic pumps only (pict. 2/W).
- Power-take-off belt pulley with engine speed. Maximum permissible torque 32 Nm, for axial and radial power-take-off (pict. 2/R).
- Sense of rotation see picture 1 and 2.
- Engine flangeable at flywheel-side.

## Engine models

- Model . M41: up to 3000 r.p.m.
- Model . M41Z: up to 3000 r.p.m. with additional balancing shaft "Z" (pict. 3).  
(deduct the required absorbed power for the balancing shaft in your calculation, depending on cylinders 0.3-1.5 kW)

## Engine Variants (pict. 4/5)

- Variant III: Crankhandle start on governor side, heavy flywheel ( $n_{max}=2600$  r.p.m.).
- Variant XI: Electric start 12 V, standard flywheel.
- Variant XII: Electric start 12 V, heavy flywheel ( $n_{max}=2600$  r.p.m.).
- Variant XIII: Electric start 24 V, standard flywheel.
- Variant XIV: Electric start 24 V, heavy flywheel ( $n_{max}=2600$  r.p.m.).

Net weight	2M41		3M41		4M41	
	kg	lbs.	kg	lbs.	kg	lbs.
Var. III, XII, XIV	261	576	—	—	—	—
Var. XI, XIII	223	492	255	562	291	642

## Scope of Delivery of Engine

Engine tested for full load on test bench. Engine fitted with blower fan, variable speed governor, injection timer, lubricating oilfilter, dry-type airfilter, hydraulic belt tensioner, automatic stop in case of belt failure, automatic injection pump bleeding, filling device for starting oil, eye hook for transport of engine (only suitable to carry the engine weight).  
Painting in HATZ standard colours or primer.

Accessories: Tools and gaskets for 1st maintenance, instruction booklet, spare parts list and "Service International".

Further equipment included in engine variants:

- Variant III: Support for crankhandle, automatic decompression, maintenance indicator for airfilter, fuel feed pump and filter, heavy flywheel, engine brackets.
- Variant XI: Electric starter 12 V, 2.7 kW, alternator 14 V, 50 A, engine wiring, electric maintenance indicator for airfilter, oil pressure switch, fuel feed pump and fuel filter, exhaust elbow, engine brackets, additional oil sump (for 4M41 only)
- Variant XII: same as Variant XI, however heavy flywheel.
- Variant XIII: same as Variant XI, however electric starter 24 V, 4.0 kW and alternator 28 V, 40 A.
- Variant XIV: same as Variant XI, however electric starter 24 V, 4.0 kW, and alternator 28 V, 40 A, heavy flywheel.

## Additional equipment

Thanks to the complete programme of additional equipment, engine can be adapted to the special requirements of every application. As a minimum every engine needs the "additional equipment, necessary for operation". For selection of additional equipment see "Engine and Equipment Survey".

