

Isuzu Commercial Marine



6HK1WM-AB2

M2 Rating 300 HP @ 2400 RPM

Conforms to U.S. EPA Tier 2 emission regulations

Features:

- 7.8 liter displacement
- Bore and Stroke: 4.53 x 4.92
- Torque: 723 lbs./ft.
- Choice of heat exchanger cooled or keel cooled
- SAE housing for easy transmission mounting
- Electronic common rail fuel system for maximum performance
- Oversized air cleaner
- Oil filters
- Water/fuel separator
- 12 Volt electrical system
- Oil sump pump
- Deep sump oil pan
- Dry fit cylinder liners
- Glow plugs for cold start
- Zinc anode protection (for heat exchanger type)
- Several fluid service drains
- Complete instrument panel

Isuzu power. Make waves.

ISUZU

DIESEL

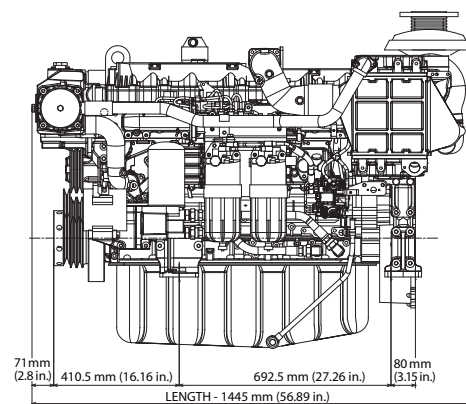
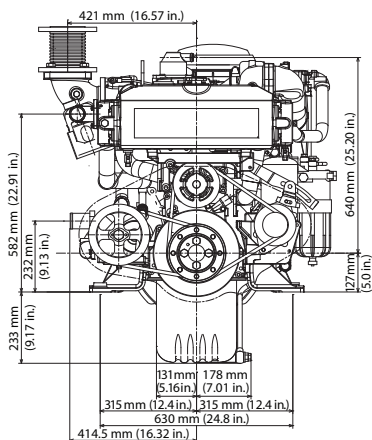
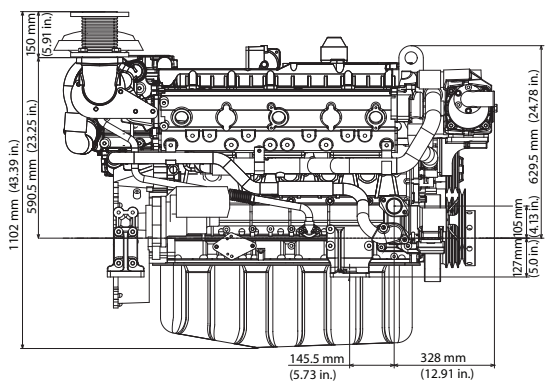

Weight Bobtail: 760 kg (1676 lbs.)

6HK1WM-AB2 Performance Curves

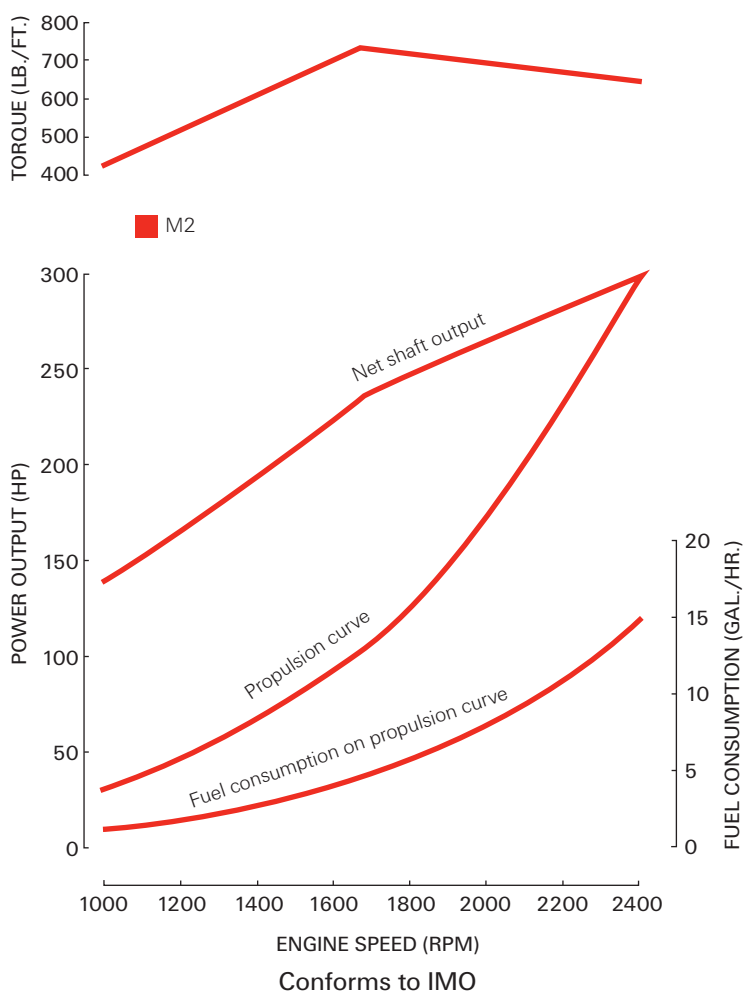

Standard Equipment:

- 12V, 3.0 kW starter
- 12V, 110 amp alternator
- SAE housing and flywheel
- Left hand rotation (looking at flywheel)
- Seawater pump
- Dry exhaust elbow
- Oil sump pump
- Owner's manual

Available Options:

- Heat exchanger or keel cooling
- Hitachi Nico marine transmissions
- Front add-on pulley
- Vibration isolators
- Extended wire harness
- Dual station panel
- Keel coolers
- Bilge pump
- Service and parts manuals

Marine Rating (M2)

Marine propulsion engines that operate at full power less than 80% of the time. Remaining 20% of the time they should operate at or below 200 rpm of maximum rated rpm. These engines usually operate less than 4,000 hours per year and include drag trawlers, offshore net fishing boats and long-line fishing boats.

Isuzu Corporate Headquarters

46401 Commerce Center Drive
 Plymouth, Michigan 48170
 Phone: 734.582.9470
 Fax: 734.455.7581